

KODIAK SNOW BLOWER

BLOWER HEAD AND POWER TRAIN
(HYDROSTATIC SERIES)

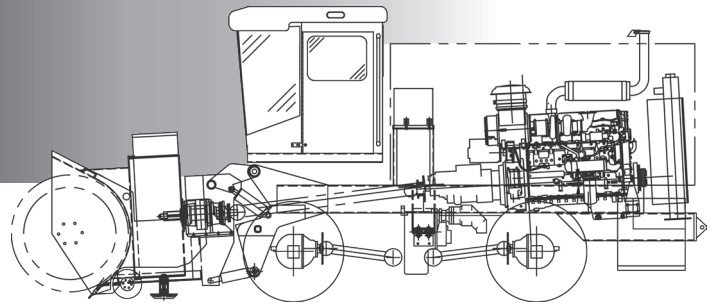

SINGLE ENGINE BLOWER

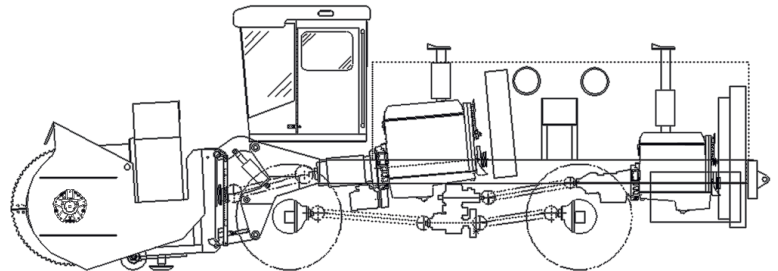

DOUBLE ENGINE BLOWER

BLOWER HEAD AND POWER TRAIN (HYDROSTATIC SERIES)

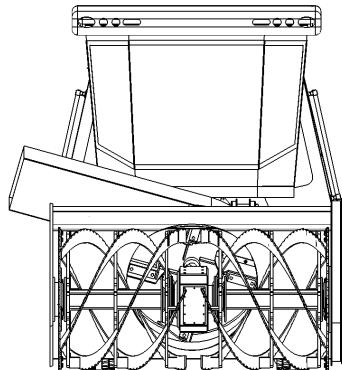

CLUTCH

Type: Full torque with SAE No. 1 housing, power engage / disengage
Size: 14 or 18 inch, three plates

HYDRAULIC SYSTEM

	Lift	Ribbon
Tank	16	16
PSI	2,000	5,000
GPM	20	2,300
Pump	Chassis	Blower
Filter	SAE J931	SAE J931
Control	Joystick	2-speed

Shut off valve at reservoir outlet • Auger drive hydrostatic warning system • Low oil level / high temp

IMPELLER SHAFTS

Heavy Duty Transmission to blower impeller • 1710-1810 Series

BLOWER ENGINE

Scania, Cummins
Horsepower at requested level: 400-1200 HP
Heated fuel / water separator

RIBBON AUGER

44-60 inch diameter • 4 blades • Hydraulic override and relief • Reversible ribbon-drive • Serrated Ribbons

IMPELLER

Size: 44-82 inch diameter
4-5 blades • Two shear bolts in

impeller shaft flange HEAD

- Abrasion resistant skid shoes • Dual hydrostatic ribbon drive with high speed motors through planetary reduction • Removable ribbon flights

AIR CLEANER

Type: Dry, two-stage with safety element

COOLING SYSTEM

Radiator Cores: Fin and tube type
Charge Air Cooling: Cooling parallel to radiator
Fan: Matched to cooling needs
Spin on Coolant Filters (optional), Silicone Radiator and Heater Hoses

CAB BLOWER

INSTRUMENTATION

- Joystick fault • Ribbon rotation direction • Ribbon Stopped • Transmission Range • Chute rotation • Float / weight transfer

TONS PER HOUR

3,000 - 11,000 TPH

BLOWER HEAD OPTIONS

Blower Head: Carbide and polymer cutting edges • Carbide skid pads • Rubber tire casters with weight transfer system • Spare impeller

paddles • Left hand fl at cast • Multi-section cutting edges • Smooth ribbons • Side cutter bars • Volute liner • Blower head liner • Spot casting chute • Quick disconnect prop shaft • 10 inch steel caster wheels or 16 inch dual pneumatic • Volute liner

Winterization: Engine oil pan heater • Engine Block heater • Arctic Package

*For reference only. The addition of options will change the listed standard dimensions and weights in some cases. For certified dimensions and weights consult Kodiak America, LLC. Specifications, descriptions and illustrations in this literature are as accurate as known at the time of publication but are subject to change without notice. Ratings are general guidelines. Actual ratings vary with application and duty cycle. Illustrations may include optional equipment and accessories but may not include all standard equipment. Consult Kodiak America, LLC for additional information.

**NOTHING
HANDLES SNOW
LIKE A
KODIAK**

